



International Journal of Advanced Research in Electrical, Electronics and Instrumentation Engineering

(A High Impact Factor, Monthly, Peer Reviewed Journal)

Website: www.ijareeie.com

Vol. 8, Issue 3, March 2019

Smart Bin by Using IOT

Dr.K.Sampathkumar^[1], S .Balamurugan^[2], D. Barathkumar^[3], R. Sathishraj^[4], V.Vijay^[5]

Head of the Department, Department of EEE, Jai Shriram Engineering College, Tirupur, Tamilnadu, India^[1]

UG Scholar, Department of EEE, Jai Shriram Engineering College, Tirupur, Tamilnadu, India^{[2]-[5]}

ABSTRACT: Internet of Things (IoT) is enabled by the rapid increase of various devices like sensors, and actuators. The Internet of Things (IoT) is a system of interrelated computing devices that are provided with unique identifiers to transfer data over a network. IoT enabled waste management is going to be implemented in Smart city. Smart city means a developed urban area that creates sustainable economic development and high quality of life by excelling in multiple key areas. The concept of the project is, the PIR sensor which is placed in the lid of the dustbin will detect the depth of the dustbin and the data will be stored in the microcontroller. The stored data is transferred to cloud server through WIFI and finally it will be displayed on the webpage.

KEYWORDS: Internet of Things (IoT), Smart Cities, Waste Management

I. INTRODUCTION

The vast amount of earth population will move to urban areas, thus, forming vast cities in future . Such cities require a smart sustainable infrastructure to manage citizen's needs and offer fundamental and more advanced services. The adoption of Future Internet technologies enhanced by the use of the Internet Protocol (IP) on numerous wireless sensors enables the Internet of Things (IoT) paradigm. When Wireless Sensor Networks (WSNs) are applied in a city, they are responsible for collecting and processing ambient information in order to upgrade legacy city infrastructure, the so-called Smart Cities (SCs). The focus of the project is monitoring and management of Garbage.

The efficient management of waste has a significant impact on the quality of life of citizens. The reason is that waste disposal has a clear connection with negative impacts in the environment and thus on citizen's health. The model is about the waste management which provides a set of services on top of an IoT infrastructure in a Smart Cities.

A definition of the concept of SC is provided in "A Smart City is a city well performing in a forward-looking way in the following fundamental components (i.e., Smart Economy, Smart Mobility, Smart Environment, Smart People, Smart Living, and Smart Governance), built on the smart combination of endowments and activities of self-decisive, independent and aware citizens".

The Internet of Things (IoT) is a system of interrelated computing devices, mechanical and digital machines, objects, animals or people that are provided with unique identifiers and the ability to transfer data over a network without requiring human-to-human or human-to-computer interaction.

II. METHODOLOGY

The proposed method for the management of wastes is efficient and time saving process. This automation of waste also reduces the human effort and consequently the cost of the whole process. This system can be implemented at any place with ease and within reasonable amount of time and reliable with long distance coverage.

2a. WIRELESS TECHNOLOGY

Wireless is the term which describes any computer network without any physical wired connection between sender and receiver. The actual meaning of wireless is to provide network connection through radio waves or microwaves to maintain communication.

Wireless technology provides the network connection over long distances without the help of long cable wires. This type of communication is also made possible by Radio Frequency (RF) waves and Infrared(IR) waves. This is used increasingly for data transmission.



ISSN (Print) : 2320 – 3765
ISSN (Online): 2278 – 8875

International Journal of Advanced Research in Electrical, Electronics and Instrumentation Engineering

(A High Impact Factor, Monthly, Peer Reviewed Journal)

Website: www.ijareeie.com

Vol. 8, Issue 3, March 2019

Advantages

The user can easily connect to the network resources at any location (Convenient to use). Users can access the internet even outside their normal working environment (Mobility). The wireless network can expand the network and can handle more number of users (Expandability).

2b. IoT Technique

The Internet of Things (IoT) is the network of devices embedded with electronics, software, sensors, actuators to connect and exchange data. Each device has unique identifiers in order to transfer data over a network. It creates opportunities for more direct integration of the physical world into computer-based systems which results in improved efficiency, accuracy and economic benefit as well as reduced human intervention. It encompasses technologies such as Smart Homes, Smart Cities and Intelligent transportation. These devices collect useful data with the help of various existing technologies and then autonomously flow the data between other devices.

III. PROPOSED MODEL DIAGRAM

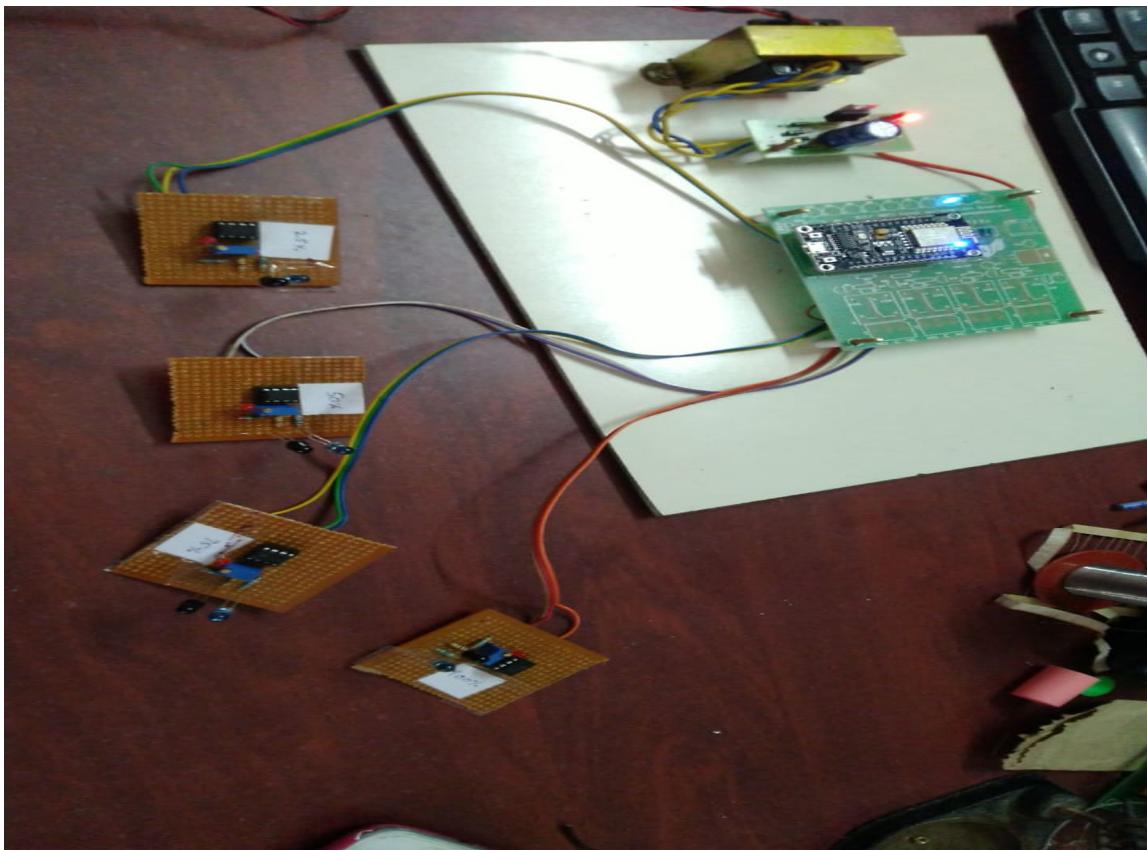

International Journal of Advanced Research in Electrical, Electronics and Instrumentation Engineering

(A High Impact Factor, Monthly, Peer Reviewed Journal)

Website: www.ijareeie.com

Vol. 8, Issue 3, March 2019

3.1 INPUT DIAGRAM

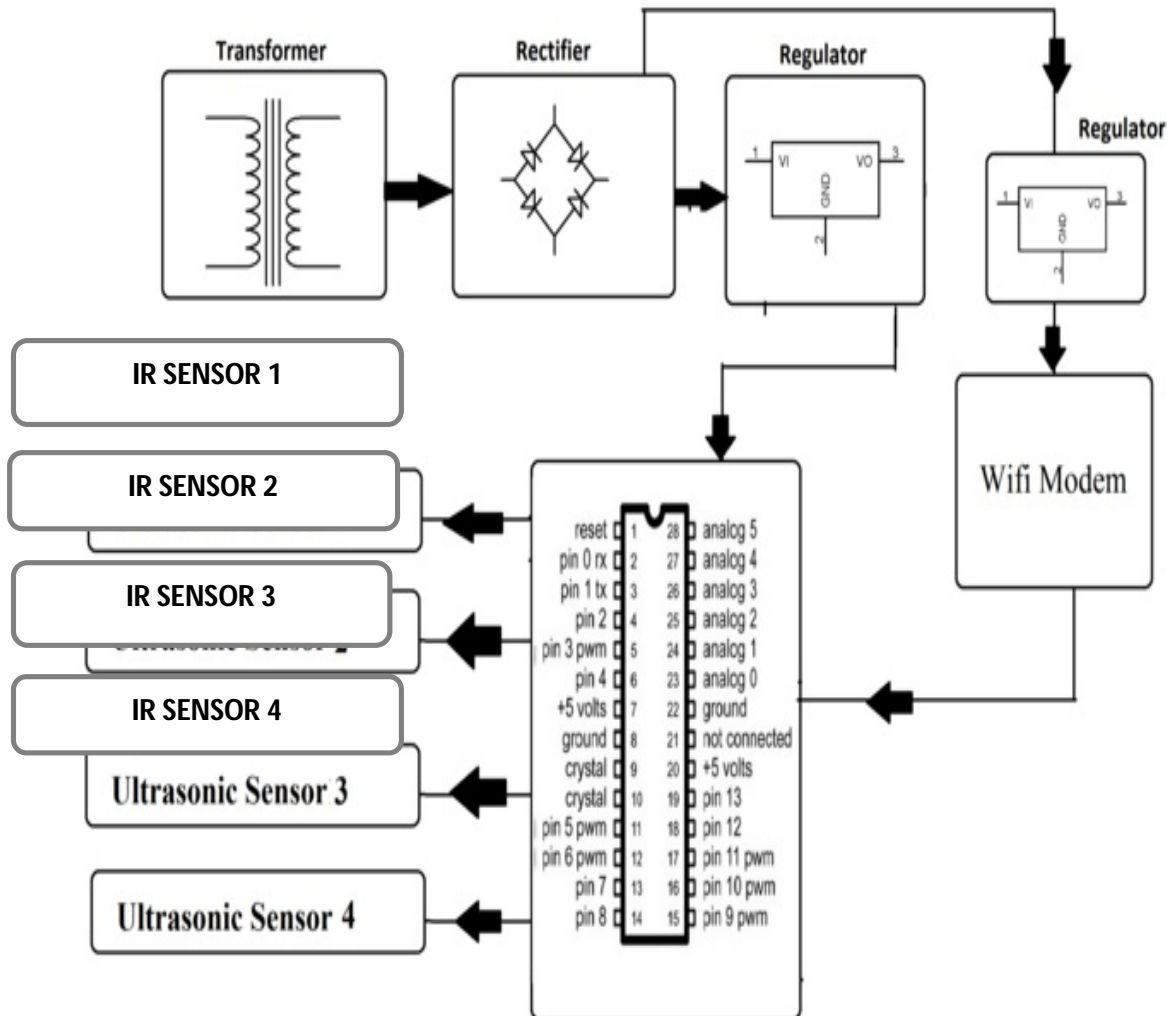

The initial work is to fix an PIR sensor on the lid of the dustbin to detect the depth of the dustbin.

Then a microcontroller is also placed on the lid to store the collected information and the collected information from the microcontroller is transferred to the SQL DATABASE with the help of WIFI (Refer Figure 3.1).

The information will be retrieved from SQL (Structured Query Language) DATABASE using a specific host IP address(URL) and create a webpage in order to view the retrieved information.

3.2 OUTPUT DIAGRAM

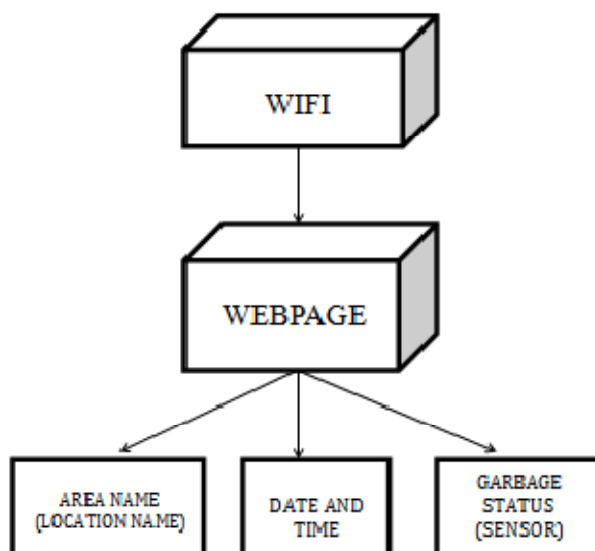

Figure 3.2 Webpage Display

The webpage displays the area name(location name), garbage status(sensor status) and date and time of any particular Street. The readings can also be downloaded for future use. Finally the user can logout from the webpage. A Graphical Interchange Format(GIF) of the dustbin will be displayed on the webpage(Refer Figure3.2).

IV. MODULE DESCRIPTION

4.1 IR sensor

An infrared sensor is an electronic device,that emits in order to sense some aspects of the surroundings.

An IR sensor can measure the heat of an object as well as detects the motion These types of sensors measures only infrared radiation, rather than emitting it that is called as a passive IR sensor.

Usually in the infrared spectrum, all the objects radiate some form of thermal radiations. These types of radiations are invisible to our eyes, that can be detected by an infrared sensor.

The emitter is simply an IR LED (Light Emitting Diode) and the detector is simply an IR photodiode which is sensitive to IR light of the same wavelength as that emitted by the IR LED. When IR light falls on the photodiode, The resistances and these output voltages, change in proportion to the magnitude of the IR light received.

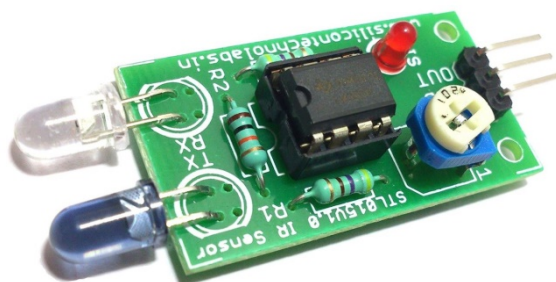

Fig 4.1.1 IR sensor



International Journal of Advanced Research in Electrical, Electronics and Instrumentation Engineering

(A High Impact Factor, Monthly, Peer Reviewed Journal)

Website: www.ijareeie.com

Vol. 8, Issue 3, March 2019

4.2 Node MCU ESP 8266

The microcontroller used is NodeMCU(ESP 8266). The ESP8266 module is aIoT device consisting of a 32-bit ARM microprocessor with support of WIFI network and built-in flash memory.

The input given to the microcontroller is power supply(i.e.,+5V DC).Initially 230 volt AC is converted into 12 volt AC using Stepdown Transformer(Refer Figure 4.2b).Then the 12 volt AC is converted to 9 volt DC using Rectifier(Diode).Finally, the 9 volt DC is converted to +5volt DC using Regulator 7805 which will be the input to the NodeMCU(ESP 8266) microcontroller.

The data which have been retrieved from the sensor will be stored in microcontroller.

4.3 STORING DATA

The data stored in the microcontroller is transferred to the SQL Database through WiFi.

The WiFi is utilized with the help of inbuilt WiFi in the microcontroller.

Relational Database Management System (RDBMS) is the basis for SQL. MySQL is a popular open source relational database management system (RDBMS) for web-based applications.

MySQL helps in optimizing and maintaining databases .For accessing database from MY SQL using Cloud Server (Refer Figure 4.3)

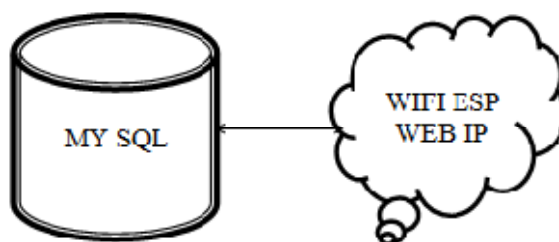

Figure 4.3 Connections between SQL Database and Cloud Server

4.4 WEB APPLICATION DEVELOPMENT

The use of scripting language is required for webpage development. It should be implemented both at the server end and client end. A scripting language known as PHP(Hypertext Preprocessor) is used because of its ability to interact with database systems. The most commonly used scripting language is Hypertext Preprocessor(PHP).The webpage displays the Area name(Location name),date and time and garbage status(Sensor Readings) of any particular Street.

V. CONCLUSION AND FUTURE ENHANCEMENTS

This survey's focus is on more energy-efficient Internet of Things (IoT) as an enabler of various applications including waste management.

The work presents the efforts for the intelligent transportation within the context of Internet of Things (IoT) and Smart Cities for waste collection.

In real time, this setup can be implemented in the environment. This set up can also be implemented in Industry based areas .

The future work may be implemented by interfacing the devices with google maps to find the optimal(shortest) path. The collected waste can also be recycled for future use.



ISSN (Print) : 2320 – 3765
ISSN (Online): 2278 – 8875

International Journal of Advanced Research in Electrical, Electronics and Instrumentation Engineering

(A High Impact Factor, Monthly, Peer Reviewed Journal)

Website: www.ijareeie.com

Vol. 8, Issue 3, March 2019

REFERENCES

1. Alam, H., 2016. Waste bins to make a cleaner South Dhaka. [Online] Available at: <http://www.thedailystar.net/city/waste-bins-make-cleaner-south-dhaka-1215094> [Accessed 29 October 2016].
2. Anon., 2005. THE STUDY ON THE SOLID WASTE MANAGEMENT IN DHAKA CITY, Dhaka:
3. Pacific Consultants International Yachiyo Engineering Co., Ltd..
4. Anon., 2016. Monitoring Waste to Minimize Waste at the University of Massachusetts
5. Amherst, Massachusetts: s.n.
6. Anon., 2016. Trash bins installed in city offer little to users. [Online]
7. Available at: <http://www.thefinancialexpress-bd.com/2016/09/16/46105/Trash-bins->
8. Alam, H., 2016. Waste bins to make a cleaner South Dhaka. [Online]
9. Available at: <http://www.thedailystar.net/city/waste-bins-make-cleaner-south-dhaka-1215094> [Accessed 29 October 2016].
10. Anon., 2005. THE STUDY ON THE SOLID WASTE MANAGEMENT IN DHAKA CITY, Dhaka:
11. Pacific Consultants International Yachiyo Engineering Co., Ltd..
12. Anon., 2016. Monitoring Waste to Minimize Waste at the University of Massachusetts
13. Amherst, Massachusetts: s.n.
14. Anon., 2016. Trash bins installed in city offer little to users. [Online]
15. Available at: [http://www.thefinancialexpress-bd.com/2016/09/16/46105/Trash-bins-Alam, H., 2016. Waste bins to make a cleaner South Dhaka. \[Online\]](http://www.thefinancialexpress-bd.com/2016/09/16/46105/Trash-bins-Alam, H., 2016. Waste bins to make a cleaner South Dhaka. [Online])
16. Available at: <http://www.thedailystar.net/city/waste-bins-make-cleaner-south-dhaka-1215094>
17. [Accessed 29 October 2016].
18. Anon., 2005. THE STUDY ON THE SOLID WASTE MANAGEMENT IN DHAKA CITY, Dhaka:
19. Pacific Consultants International Yachiyo Engineering Co., Ltd..
20. Anon., 2016. Monitoring Waste to Minimize Waste at the University of Massachusetts Amherst, Massachusetts: s.n.
21. Anon., 2016. Trash bins installed in city offer little to users. [Online]
22. Available at: <http://www.thefinancialexpress-bd.com/2016/09/16/46105/Trash-bins-Mohammad Ali installed-in-city-offer-little-to-users>
23. [Accessed 10 November 2016].
24. Anon., n.d. Bigbelly International Footprint. [Online] Available at: <http://bigbelly.com/international/>
25. Belal Chowdhury, M. U. C., 2007. RFID-based Real-time Smart Waste Management
26. System. Australasian Telecommunication Networks and Applications Conference, pp. 175-180.
27. Hasanuzzaman Zaman and Rokonzaman, P., n.d. ACHIEVING DIGITAL BANGLADESH BY 2021 AND BEYOND, Dhaka: s.n.
28. Joseph Bradley, J. B. D. H., 2013. Embracing the Internet of Everything, s.l.: s.n. Rahman, L., 2015. Digital Bangladesh: Dreams and reality. [Online]
29. Available at: <http://www.thedailystar.net/supplements/24th-anniversary-the-daily-star-part-1/digital-bangladesh-dreams-and-reality-73118>
30. [Accessed 29 November 2016].
31. Rahman, O., 2016. Did You Take my dustbin?. [Online]
32. Available at: <http://www.thedailystar.net/star-weekend/did-you-take-my-dustbin-1222693>
33. [Accessed 20 October 2016].
34. S M Alauddin 31 October, 2. I. A., 2015. Domestic Waste Management in Dhaka City:
35. Problems and Potentials. [Online]
36. Available at: <http://www.daily-sun.com/printversion/details/87189/Domestic-Waste-Management-in-Dhaka-City:-Problems-and-Potentials>
37. [Accessed 20 November 2016].
38. Tamzid Ahmed Chowdhury, S. R. A., 2006. WASTE MANAGEMENT IN DHAKA CITY-A
39. THEORETICAL MARKETING MODEL. BRAC University Journal, Volume III, pp. 101-111.
40. Tusher, H. J., 2011. Dhaka set to split into two. [Online]
41. Available at: <http://www.thedailystar.net/news-detail-206982>
42. [Accessed 15 November 2016].
43. Alam, H., 2016. Waste bins to make a cleaner South Dhaka. [Online]
44. Available at: <http://www.thedailystar.net/city/waste-bins-make-cleaner-south-dhaka-1215094>
45. 1215094
46. [Accessed 29 October 2016].
47. Anon., 2005. THE STUDY ON THE SOLID WASTE MANAGEMENT IN DHAKA CITY, Dhaka:
48. Pacific Consultants International Yachiyo Engineering Co., Ltd..
49. Anon., 2016. Monitoring Waste to Minimize Waste at the University of Massachusetts
50. Amherst, Massachusetts: s.n.
51. Anon., 2016. Trash bins installed in city offer little to users. [Online]
52. Available at: <http://www.thefinancialexpress-bd.com/2016/09/16/46105/Trash-bins-Mohammad Ali installed-in-city-offer-little-to-users>
53. installed-in-city-offer-little-to-users
54. [Accessed 10 November 2016].
55. Anon., n.d. Bigbelly International Footprint. [Online]
56. Available at: <http://bigbelly.com/international/>
57. Belal Chowdhury, M. U. C., 2007. RFID-based Real-time Smart Waste Management
58. System. Australasian Telecommunication Networks and Applications Conference, pp. 175-
59. 180.



ISSN (Print) : 2320 – 3765
ISSN (Online): 2278 – 8875

International Journal of Advanced Research in Electrical, Electronics and Instrumentation Engineering

(A High Impact Factor, Monthly, Peer Reviewed Journal)

Website: www.ijareeie.com

Vol. 8, Issue 3, March 2019

60. HasanuzzamanZaman and Rokonuzzaman, P., n.d.ACHIEVING DIGITAL BANGLADESH BY
61. 2021 AND BEYOND, Dhaka: s.n.
62. Joseph Bradley, J. B. D. H., 2013. Embracing the Internet of Everything, s.l.: s.n.
63. Rahman, L., 2015. Digital Bangladesh: Dreams and reality. [Online]
64. Available at: <http://www.thedailystar.net/supplements/24th-anniversary-the-daily-star-part-1/digital-bangladesh-dreams-and-reality-73118>
65. [Accessed 29 November 2016].
66. Rahman, O., 2016. Did You Take my dustbin?.[Online]
67. Available at: <http://www.thedailystar.net/star-weekend/did-you-take-my-dustbin-1222693>
68. [Accessed 20 October 2016].
69. S M Alauddin 31 October, 2. 1. A., 2015. Domestic Waste Management in Dhaka City: Problems and Potentials.[Online]
70. Available at: <http://www.daily-sun.com/printversion/details/87189/Domestic-Waste-Management-in-Dhaka-City:-Problems-and-Potentials>
71. [Accessed 20 November 2016].
72. Tamzid Ahmed Chowdhury, S. R. A., 2006. WASTE MANAGEMENT IN DHAKA CITY-A THEORETICAL MARKETING MODEL.BRAC University Journal, Volume III, pp. 101-111.
73. Tusher, H. J., 2011.Dhaka set to split into two. [Online] Available at: <http://www.thedailystar.net/news-detail-206982>
74. [Accessed 15 November 2016].
75. Alam, H., 2016. Waste bins to make a cleaner South Dhaka. [Online] Available at: <http://www.thedailystar.net/city/waste-bins-make-cleaner-south-dhaka-1215094> [Accessed 29 October 2016].
76. Anon., 2005.THE STUDY ON THE SOLID WASTE MANAGEMENT IN DHAKA CITY, Dhaka: Pacific Consultants International Yachiyo Engineering Co., Ltd..
77. Anon., 2016. Monitoring Waste to Minimize Waste at the University of Massachusetts Amherst, Massachusetts: s.n.
78. Anon., 2016.Trash bins installed in city offer little to users. [Online]
79. Available at: <http://www.thefinancialexpress-bd.com/2016/09/16/46105/Trash-bins-Mohammad-Ali-installed-in-city-offer-little-to-users> [Accessed 10 November 2016].
80. Anon., n.d.Bigbelly International Footprint.[Online]
81. Available at: <http://bigbelly.com/international/>
82. BelalChowdhury, M. U. C., 2007. RFID-based Real-time Smart Waste Management
83. System.Australasian Telecommunication Networks and Applications Conference, pp. 175-180.
84. HasanuzzamanZaman and Rokonuzzaman, P., n.d.ACHIEVING DIGITAL BANGLADESH BY 2021 AND BEYOND, Dhaka: s.n.
85. Joseph Bradley, J. B. D. H., 2013. Embracing the Internet of Everything, s.l.: s.n.
86. Rahman, L., 2015. Digital Bangladesh: Dreams and reality. [Online]
87. Available at: <http://www.thedailystar.net/supplements/24th-anniversary-the-daily-star-part-1/digital-bangladesh-dreams-and-reality-73118>
88. [Accessed 29 November 2016].
89. Rahman, O., 2016. Did You Take my dustbin?.[Online] Available at: <http://www.thedailystar.net/star-weekend/did-you-take-my-dustbin-1222693>
90. 1222693
91. [Accessed 20 October 2016].
92. S M Alauddin 31 October, 2. 1. A., 2015. Domestic Waste Management in Dhaka City: Problems and Potentials.[Online]
93. Available at: <http://www.daily-sun.com/printversion/details/87189/Domestic-Waste-Management-in-Dhaka-City:-Problems-and-Potentials>
94. [Accessed 20 November 2016].
95. Tamzid Ahmed Chowdhury, S. R. A., 2006. WASTE MANAGEMENT IN DHAKA CITY-A
96. THEORETICAL MARKETING MODEL.BRAC University Journal, Volume III, pp. 101-111.
97. Tusher, H. J., 2011.Dhaka set to split into two. [Online]
98. Available at: <http://www.thedailystar.net/news-detail-206982> [Accessed 15 November 2016].
99. "Smart bin: Smart Waste Management System", 2015 IEEE Tenth International Conference on Intelligent Sensors, Sensor Networks and Information Processing (ISSNIP) Demo and Video. Singapore, 7-9 April 2015.
100. Abhay Shankar baradwaj, Rainer Rego, "IoT Based Solid Waste Management System" A conceptual approach withan architectural solution as a smart city application,2016,1-6
101. Dr.N.SathishKumar,
102. B.,Vijaylakshmi,R.Jenifer,,A.Shankar , "IOT Based Smart Garbage Alert System Using Arduino UNO,2016 IEEE Region 10 Conference,Page no 1028-1034.
103. Prakash, Prabu, "Iot based waste management for smart city", International journal of Innovative Reseach in Computer and Communication Engineering, vol.4, Issue 2, February 2016, 1267-1274.
104. MansiWaikar, RajatLashkare, RushabhMutha, ShreekarVidwans, "A Review on Solid Waste management usingsmart bin", International journal of Innovative Reseach in Computer and Communication Engineering, vol.4, Issue 11, November 2016, 19203-19207.